

CHANFREINEUSE POUR PLINTHES MOD.: BRX7



Caractéristiques principales:

- Longueur totale de la machine:.....4000 mm
- Largeur maxi:.....640 mm
- Hauteur maxi:.....1632 mm
- Puissance totale installée:.....16HP env.
- Tension de travail:.....400V AC
- Tension de service:.....24V DC
- Vitesse du tapis:.....1 à 5 m/minute réglable
- Consommation d'air:.....0.5 à 1 m³/heure
- POIDS TOTAL:.....1750 kg.

Dimensions:

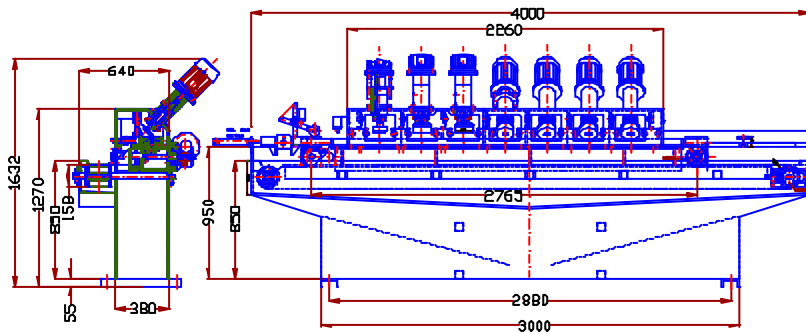

PRETOM MAQUINARIA, S.L.
CONSTRUCCIÓN DE MAQUINARIA
PARA TERRAZO Y MÁRMOL
C/Lugo, s/n-TOMELLOSO-ESPAÑA
Tel.: +34926506570-+34926512912
Fax: +34926506562
<http://www.pretom.com>
e-mail: pretom@pretom.com

