

CHARIOT AUTOMATIQUE MOD.: SCA 860



Caractéristiques principales:

Longueur totale de la machine:	3150 mm
Largeur maxi.:	2660 mm
Hauteur maxi.:	2345 mm
Puissance totale installé:	9.5 HP
Tension de travail:	400V AC
Tension de service:	24 V DC
 POIDS TOTAL:	 3800 Kg

Dimensions:

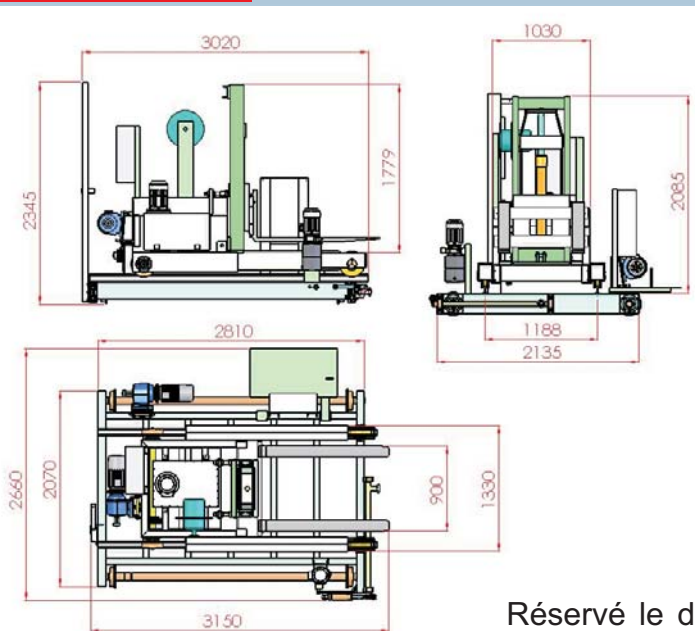

PRENSAS DE TOMELLOSO, S.A.
CONSTRUCCIÓN DE MAQUINARIA
PARA TERRAZO Y MÁRMOL
 C/ Lugo, s/n - TOMELLOSO - ESPAÑA
 Tel.: +34 926 506 570 - +34 926 512 912
 Fax: +34 926 506 562
<http://www.pretom.com>
 e-mail: pretom@pretom.com

