

AUTOMATIC CHARIOT MOD.: SCA 860



Main features:

Total long of the machine: 3150 mm
 Maximun widht: 2660 mm
 Maximun heght: 2345 mm
 Installed total power: 9.5 HP
 Work tension: 400V AC
 Tension of service: 24 V DC

TOTAL WEIGHT: 3800 Kg

Dimensions:

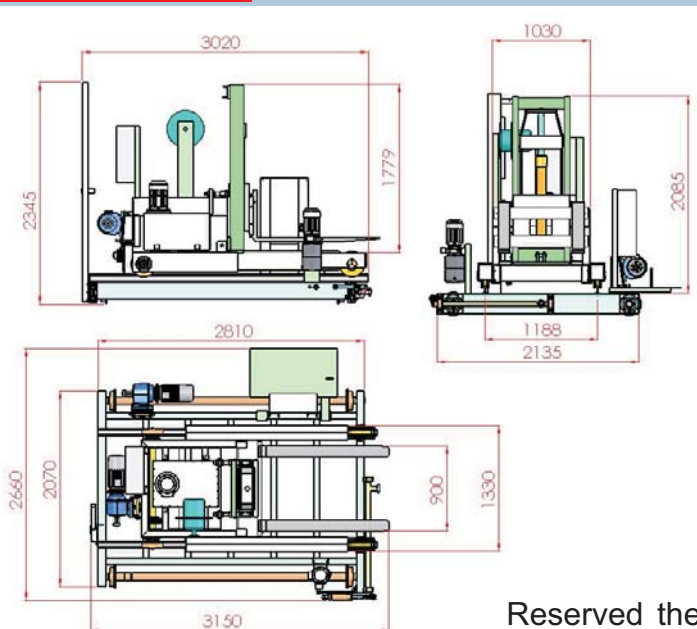

PRENSAS DE TOMELLOSO, S.A.
CONSTRUCCIÓN DE MAQUINARIA
PARA TERRAZO Y MÁRMOL
 C/ Lugo, s/n - TOMELLOSO - ESPAÑA
 Tel.: +34 926 506 570 - +34 926 512 912
 Fax: +34 926 506 562
 http://www.pretom.com
 e-mail: pretom@pretom.com

