

CHARIOT AUTOMATIQUE MOD. SCA 1500



Caractéristiques principales:

Longueur totale de la machine:	3830 mm
Largeur maxi:	3050 mm
Hauteur maxi:	2400 mm
Puissance totale installé:	11'5 CV
Tension de travail:	400 VAC
Tension de service:	24 VDC
POIDS TOTAL:	3800 Kg

Dimensions:

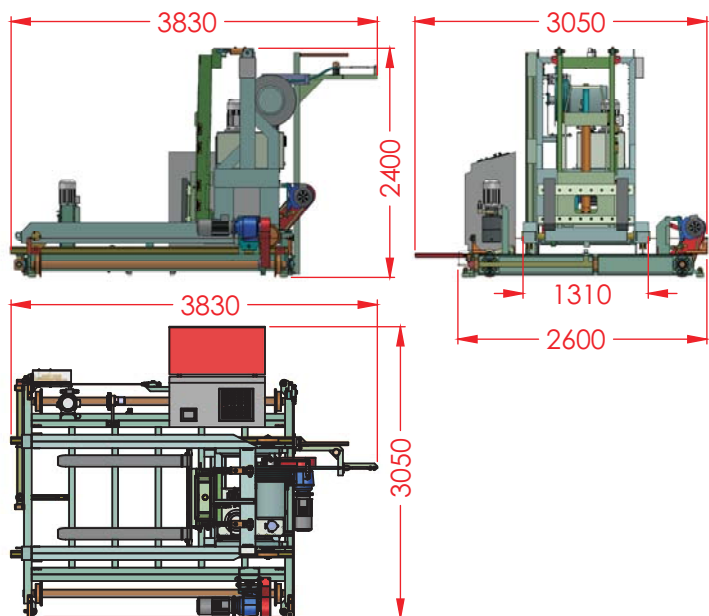

PRENSAS DE TOMELLOSO, S.A.
CONSTRUCCIÓN DE MAQUINARIA
PARA TERRAZO Y MÁRMOL
 C/ Lugo, s/n - TOMELLOSO - ESPAÑA
 Tel.: +34 926 506 570 - +34 926 512 912
 Fax: +34 926 506 562
<http://www.pretom.com>
 e-mail: pretom@pretom.com

