

AUTOMATIC CHARIOT MOD. SCA 1500



Principal characteristics:

Total long of the machine:	3830 mm
Maximum width:	3050 mm
Maximum height:	2400 mm
Total installed power:	11.5 CV
Work tension:	400 VAC
Tension of service:	24 VDC
TOTAL WEIGHT:	3800 Kg

Dimensions:

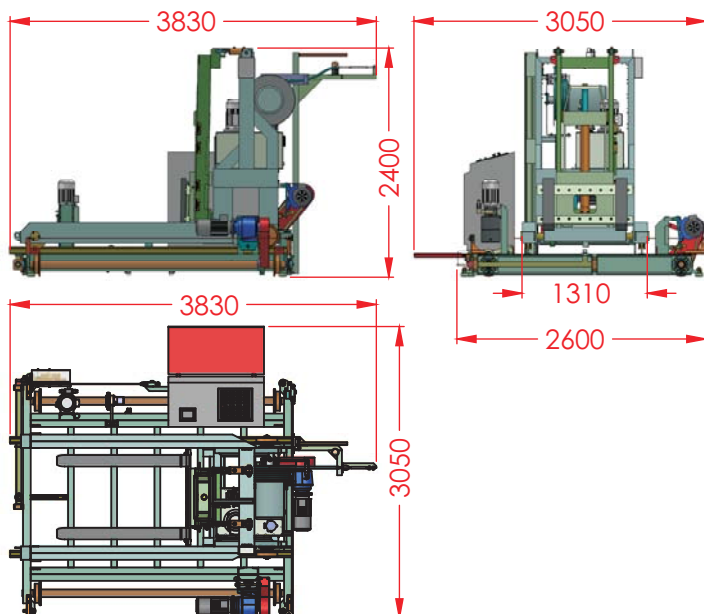

PRENSAS DE TOMELLOSO, S.A.
CONSTRUCCIÓN DE MAQUINARIA
PARA TERRAZO Y MÁRMOL
 C/ Lugo, s/n - TOMELLOSO - ESPAÑA
 Tel.: +34 926 506 570 - +34 926 512 912
 Fax: +34 926 506 562
<http://www.pretom.com>
 e-mail: pretom@pretom.com

