

DOSEUR DE PATE



Caractéristiques principales:

Longueur totale de la machine:	1959 mm
Largeur maxi:	1155 mm
Hauteur maxi:	2564 mm
Puissance totale installé:	10 CV
Tension de travail:	400 VAC
Tension de service:	24 VDC

POIDS TOTAL: 1000 Kg

Dimensions:

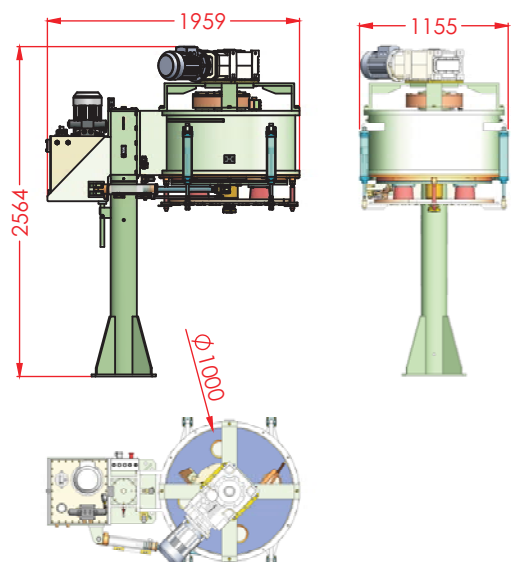

PRENSAS DE TOMELLOSO, S.A.
CONSTRUCCIÓN DE MAQUINARIA
PARA TERRAZO Y MÁRMOL

C/ Lugo, s/n - TOMELLOSO - ESPAÑA
 Tel.: +34 926 506 570 - +34 926 512 912
 Fax: +34 926 506 562
<http://www.pretom.com>
 e-mail: pretom@pretom.com

