

NETTOYEUSE MOD. LAV-3



Caractéristiques principales:

Longueur totale de la machine:	4050 mm
Largeur maxi.:	1550 mm
Hauteur maxi.:	2200 mm
Puissance totale installée:	17 HP
Tension de travail:	400 VAC
Tension de service:	24 VDC
Vitesse du tapis:	1 à 6 m/min. Réglable
POIDS TOTALE:	2500 KG.

Dimensions:

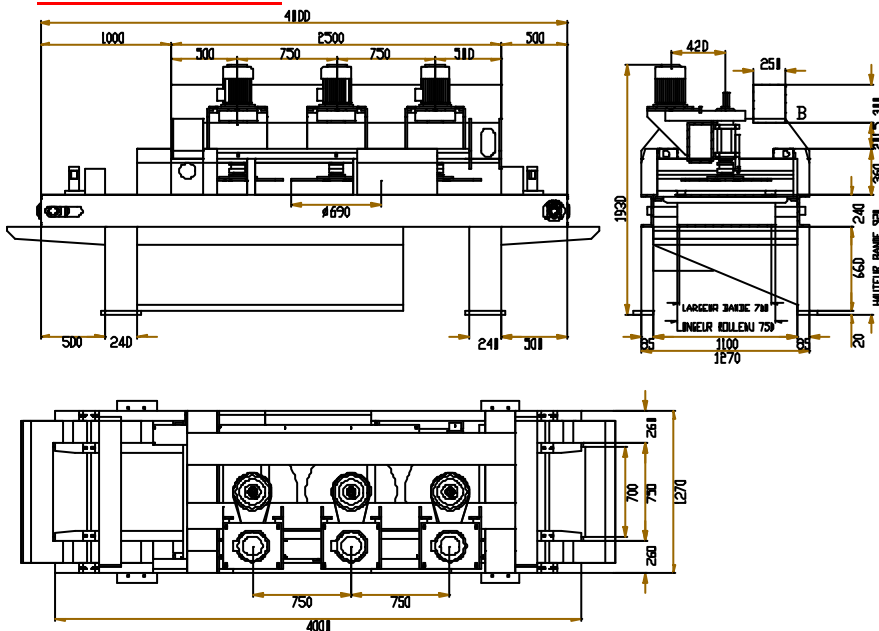

PRETOM MAQUINARIA, S.L.
CONSTRUCCIÓN DE MAQUINARIA
PARA TERRAZO Y MÁRMOL
 C/Lugo, s/n - TOMELLOSO - ESPAÑA
 Tel.: +34926506570 - +34926512912
 Fax: +34926506562
 http://www.pretom.com
 e-mail: pretom@pretom.com

