

# WASHING MACHINE MOD. LAV-3

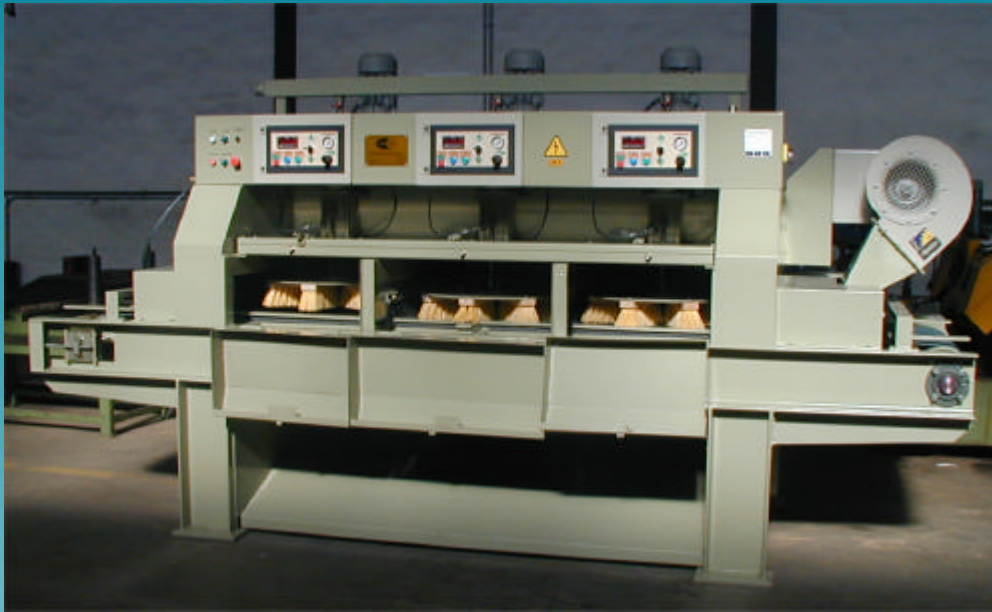

## Characteristic main:

Total long of the machine:.....4050 mm  
 Maximunwidth:.....1550mm  
 Maximun height:.....2200mm  
 Installed totalpower:.....17 HP  
 Work tension:.....400 VAC  
 Tension of service:.....24 VDC  
 Speed ofband:.....1 a 6 m/min. Approx.  
 TOTAL WEIGHT:.....2500 KG.

## Dimensions:

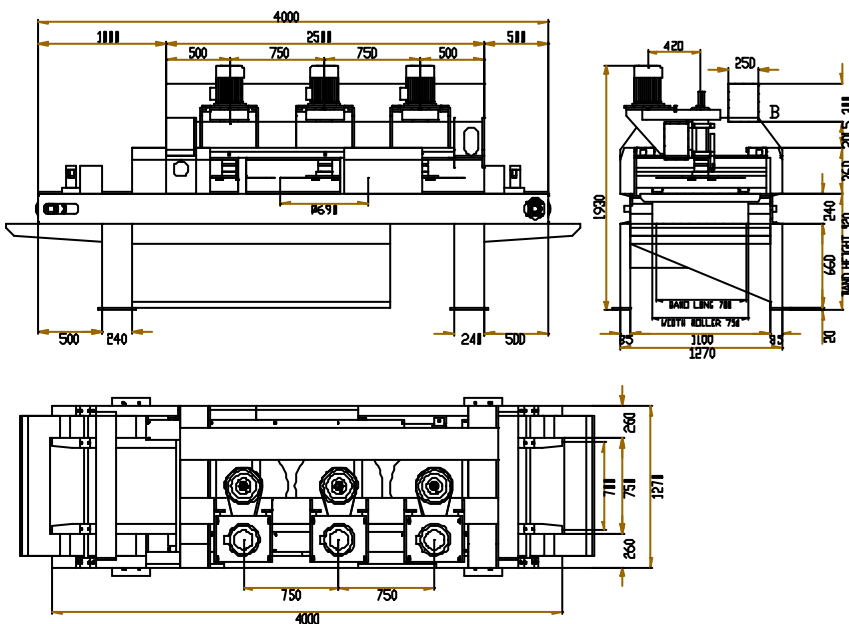

**PRETOMMAQUINARIA,S.L.**  
 CONSTRUCCIÓNDEMAQUINARIA  
 PARATERRAZOYMÁRMOL  
 C/Lugo,s/n-TOMELLOSO-ESPAÑA  
 Tel.:+34926506570-+34926512912  
 Fax:+34926506562  
 http://www.pretom.com  
 e-mail:pretom@pretom.com

