

# PRESS MOD.: P1 - 400



**Characteristic main:**

Diameter of the machine:.....3000 mm  
 Maximunwidth:.....2380 mm  
 Installed totalpower:.....55 HP Approx.  
 Work tension:.....400 VAC  
 Tension of service:.....24 VDC  
 Consumption o f compressed air, filtrate and dry.....  
 .....10 m3/hour to a pressure of 5 to 8 bar.  
 TOTAL WEIGHT:.....14100 KG.

**Recommended formats:**

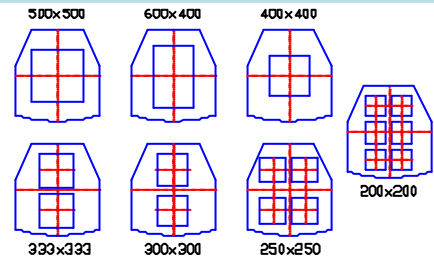

**Dimensions:**

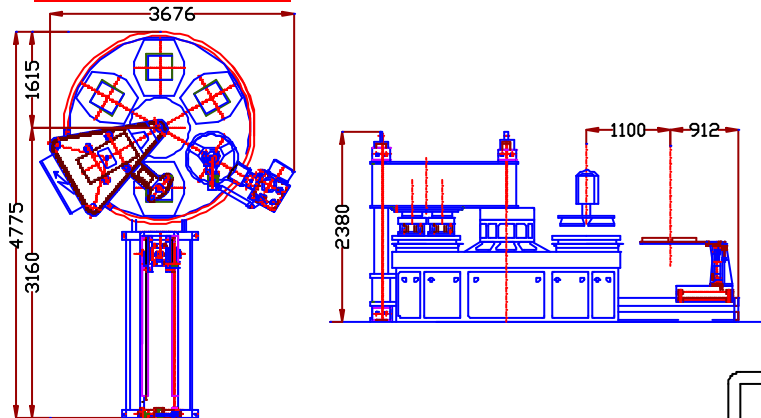

**PRETOMMAQUINARIA, S.L.**  
**CONSTRUCCIÓNDEMAQUINARIA**  
**PARATERRAZOYMÁRMOL**  
 C/Lugo, s/n- TOMELLOSO-ESPAÑA  
 Tel.: +34926506570-+34926512912  
 Fax: +34926506562  
<http://www.pretom.com>  
 e-mail: [pretom@pretom.com](mailto:pretom@pretom.com)

