

PRESSE MOD.: P1-600



Caractéristiques principales:

Diamètre de la machine:3740 mm
 Hauteur maxime:2960 mm
 Puissance totale installée:60.75 kw
 Tension de travail:400 VAC
 Tension de service:24 VDC
 Consommation d'air comprimé, filtré y séché:
 15 m3/h. Pression de service: 5 á 8 bar.
 POIDS TOTAL:32550 kg.

Formats recommandés:

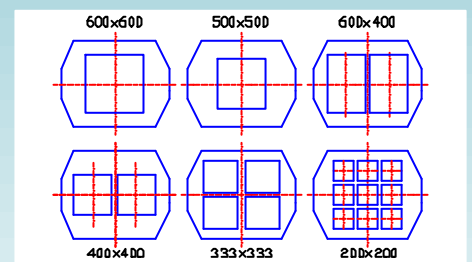

Dimensions:

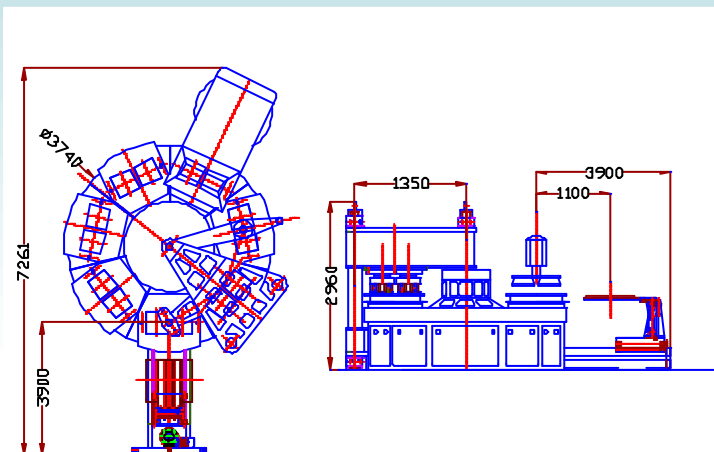

Réservé le droit à une modification sans préavis



PRETOM MAQUINARIA, S.L.
 CONSTRUCCIÓN DE MAQUINARIA
 PARA TERRAZO Y MÁRMOL
 C/Lugo, s/n - TOMELLOSO - ESPAÑA
 Tel: +34926506570 - +34926512912
 Fax: +34926506562
<http://www.pretom.com>
 e-mail: pretom@pretom.com

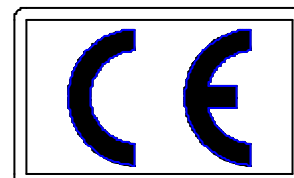

Édition 4