

# PRESS MOD.: P1-600



**Characteristic main:**

Diameter of the machine:.....3740 mm  
 Maximun height:.....2960 mm  
 Installed total power:.....60,75 kw  
 Work tension:.....400 VAC  
 Tension of service:.....24 VDC  
 Consumption of compressed air, filtrate and dry:  
 .....15m3/h. To a pressure of 5 to 8 bars.  
**TOTAL WEIGHT:.....32550 kg.**

**Recommended formats:**

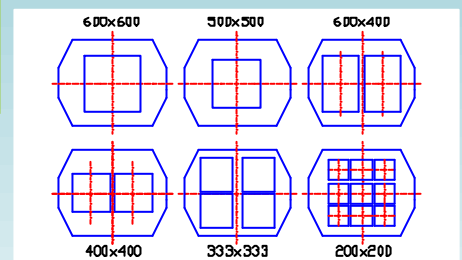

**Dimensions:**

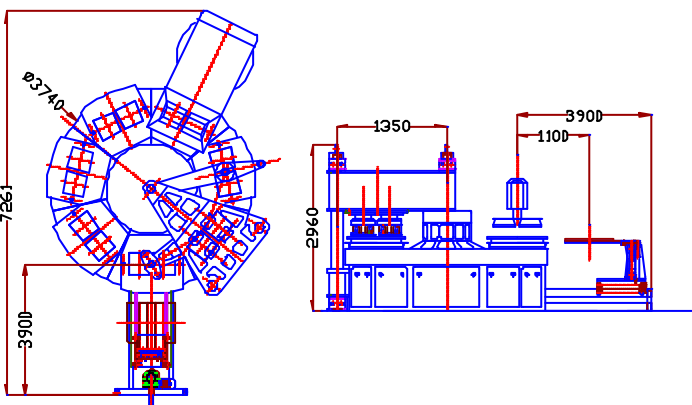

**PRETOMMAQUINARIA,S.L.**  
 CONSTRUCCIÓNDEMAQUINARIA  
 PARATERRAZOYMÁRMOL  
 C/Lugo,s/n-TOMELLOSO-ESPAÑA  
 Tel: +34926506570-+34926512912  
 Fax:+34926506562  
<http://www.pretom.com>  
 e-mail:pretom@pretom.com

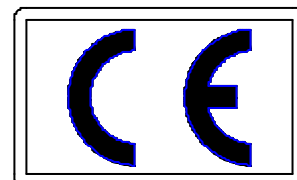

Edition 4